

B-COOL RV SERIES

Installation Manual



www.dcpowersales.com

SAFETY INSTRUCTION



Installation must be performed by a professional



Unit is heavy. Do not handle or install the unit alone.

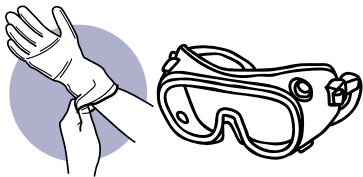

Wear goggles and gloves for the installation

CAUTION : HEAVY

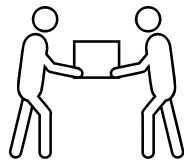

Switch off / disconnect battery before installation



Do not remove any protection provided on the unit.



EACH BOX CONTAINS



*Power Harness
(12v)*



*Remote
Controller*



Install Screws



*Power Harness
(24v)*



Air Conditioner



*Sealing Rubber
(Gasket)*



Air Diffuser

STEP 1.

Cutting the Hole

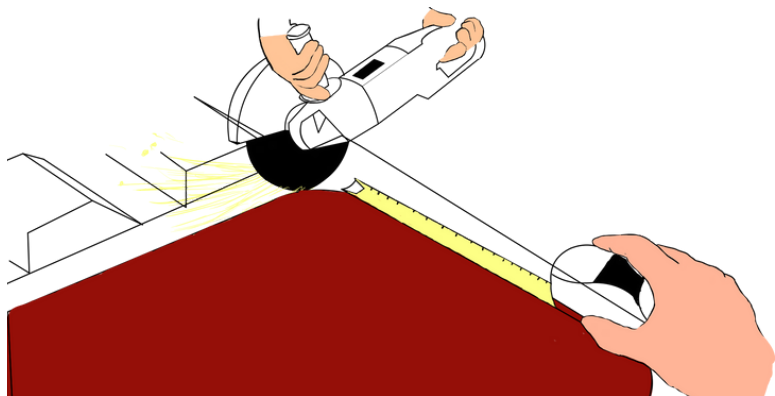

"Measure Twice, Cut Once"

Recommended Hole Cut Size :

35.56 cm x 35.56 cm
14 in x 14 in

STEP 2.

Clean Around the Cut

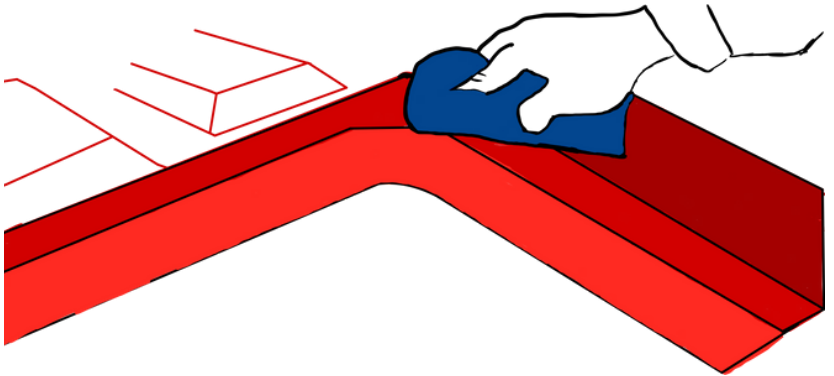

REMOVE DIRT, DUST, DEBRIS

STEP 3.

Apply Gasket



Apply Appropriate Sealant as needed.

STEP 4.

Place Air Conditioner on cut hole

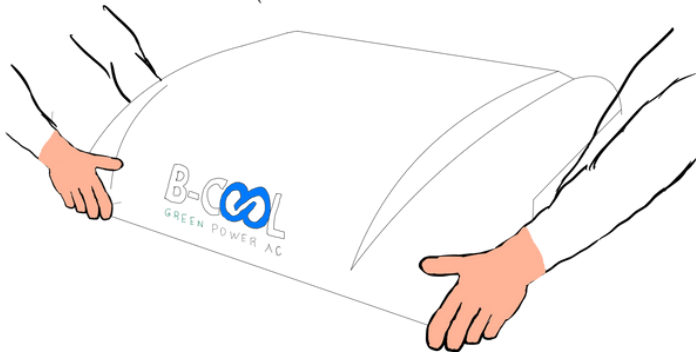

Have someone help you place the air conditioner onto the gasket.

STEP 5.

Apply the Insulation Sponge

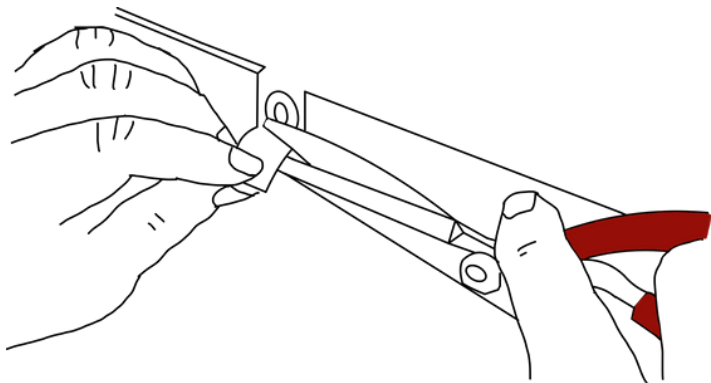

Cut the insulation sponge at the position of the four nuts.
(make four cuts)

STEP 6.

Connecting the Fixing Screws

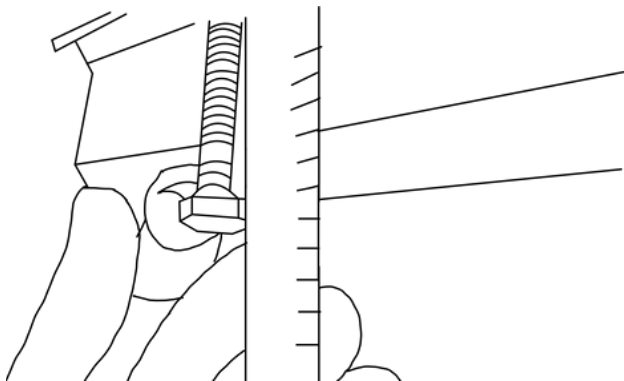

- Record the remaining length of the screw beyond the holder
- Cut off the excess length of the screws

STEP 7.

Install the Holder

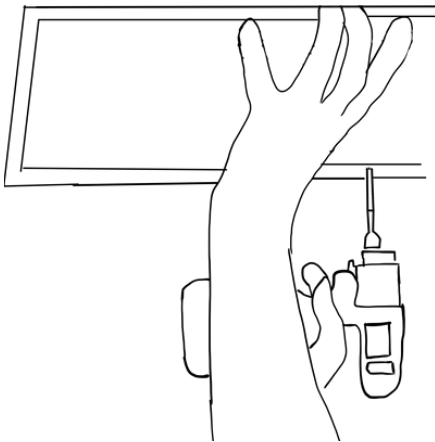

Securing rooftop air conditioner to the interior of the vehicle.

STEP 8.

Disassemble the Internal Unit

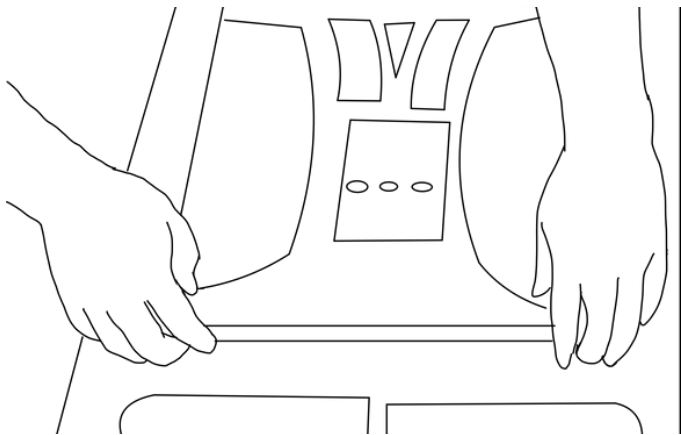

Remove the Panel first and then the air deflector

STEP 9.

Install the air guide foam



Main Foam

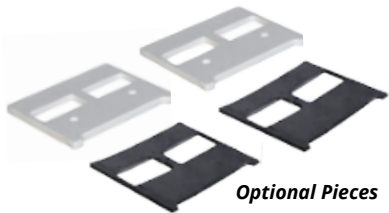

Optional Pieces

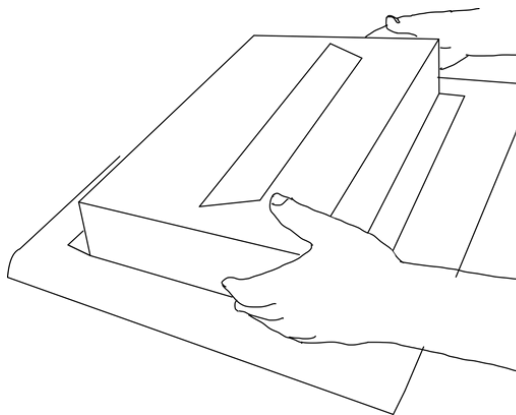

Number of the optional pieces used depends on the thickness of the roof.

STEP 10.

Passing the Wire through Internal Unit

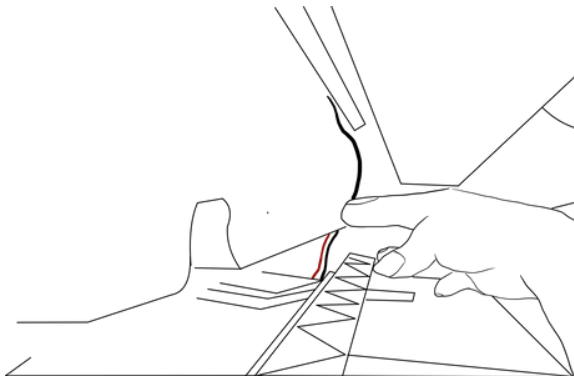

Pass the condenser fan and compressor control harness through the main part of the internal unit.

STEP 11.

Install Air Deflector onto Internal Unit

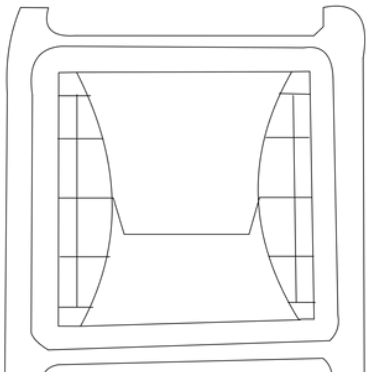

- Fasten the air deflector to the internal unit using the 4 attachable buckles on the unit.
- Connect the air deflector by using the 4 self tapping screws.

STEP 12.

Passing the Wire through air deflector

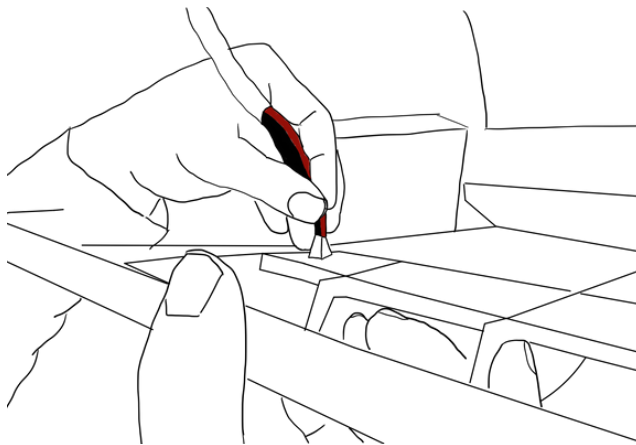

Pass the condenser fan and compressor control harness through the air deflector.

STEP 13.

Connecting the Internal Controller

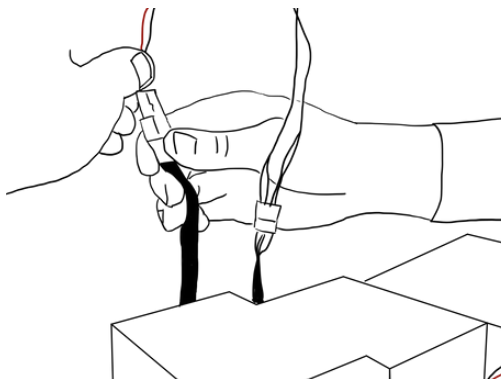
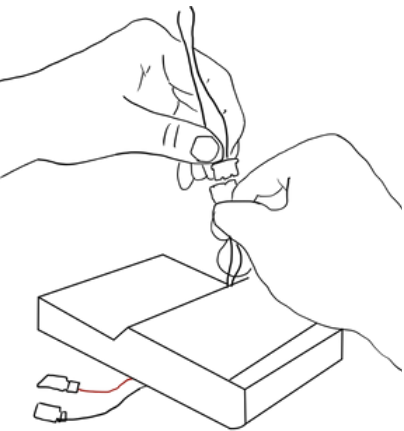

Connect the condenser harness and compressor harness to the internal controller.

STEP 14.

Installing the Internal Filters

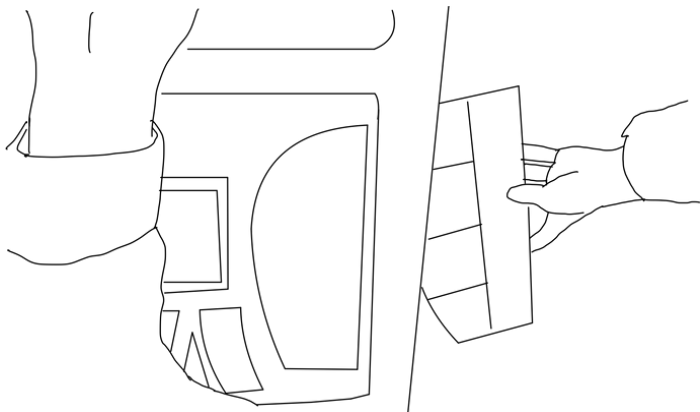

- Attach the Air Diffuser/Control Panel.
- Install the Internal Filters on both sides.

STEP 15.

Connect the Power Cable to Battery

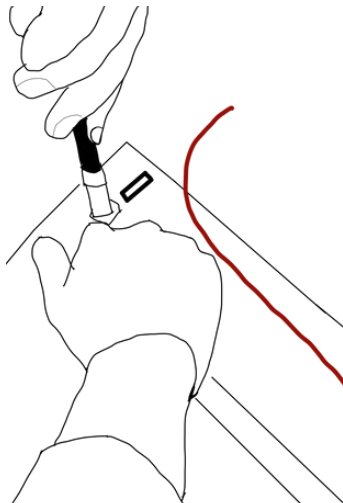
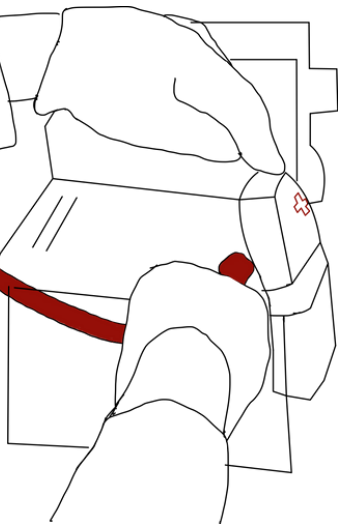

Red Wire is connected to the positive pole.
Black Wire is connected to the negative pole.

STEP 16.

Switch on the A/C

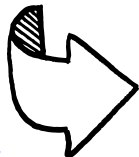

**FLIP OVER FOR
"OPERATING INSTRUCTIONS"**

RV SERIES

OPERATING MANUAL

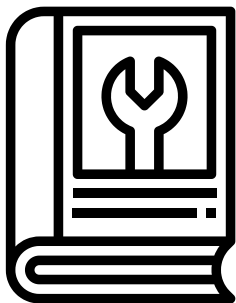

www.dcpowersales.com

OPERATING INSTRUCTIONS



CONTROL PANEL



CONTROL PANEL



REMOTE CONTROL

OPERATING INSTRUCTIONS

Turn on A/C:

Long Press the ***On / Off*** button to operate the A/C

Setting the Temperature:

- Press the down button to lower the temperature.
- Press the up button to increase the temperature.

OPERATING INSTRUCTIONS

Setting the Wind Speed:

- Press the arrow up button to enter the windspeed settings.
- Press the down button to decrease the speed.
- Press the up button to increase the speed.

OPERATING INSTRUCTIONS

Setting the Cut Off Voltage:

- Every B-COOL branded air conditioner comes with a voltage cut off feature.
- **Turn off the air conditioner**, press the **arrow up** and **arrow down** key at the **same time**. This will let you enter the voltage setting.
- Press the *DOWN* button or the UP button to lower or increase the cut off voltage

Manufacturer recommended voltage settings (if needed).

Lower the Voltage for:

12V units : 9V ~ 12V

24V units : 21V ~ 24V

TROUBLESHOOTING - AIR CONDITIONER

Condition	Solution(s)
If the cooling effect is not good	<ul style="list-style-type: none">• Select the right mode and set proper temperature and speed.• Check if there is any obstruction at the air inlet and outlet• Check if the surface of the condenser is dirty• Check refrigerant level (low pressure, high pressure).
There is water on the surface of the inside unit	When running in an environment with high humidity, water drops may form on the air outlet and core surface, which is normal.

TROUBLESHOOTING - AIR CONDITIONER

Condition	Solution(s)
The control panel displays voltage fault	<ul style="list-style-type: none">• Check battery for low voltage and verify that the power source is either 12V or 24V DC• Check if the low voltage protection value is too high
The control panel displays sensor fault	<ul style="list-style-type: none">• Check if the sensor at air inlet / outlet is plugged in correctly• Check if the display temperature is higher than normal ambient temperature. If it is, change the sensor.

TROUBLESHOOTING - AIR CONDITIONER

Condition	Solution(s)
The control panel displays <i>fan fault</i>	Check if the fan is correctly plugged in. Connect the fan with a separate 12V or 24V DC power source. If the fan doesn't work, replace fan.
The control panel displays <i>outdoor unit fault</i>	<ul style="list-style-type: none">• Check if it is short of refrigerant.• Check if the high and low voltage is within the normal range.• Check if the condenser is dirty - if so the heat dissipation is adversely affected.

TROUBLESHOOTING

*The B-COOL Rooftop units come pre-charged.
However, should a leak or an Incident occur, the following steps must be taken.*

Leak Testing:

1. Refrigerant volume (check with Glass Level)
2. If volume is low or is lower than the previous check, investigate leak by looking for traces of oil.
3. Attach the nitrogen tank to the low side port.
4. Perform a leak test by pressuring the system to 200 psi and then check for leaks at each fitting and connection.
5. The system should hold pressure for at least 15 minutes.
6. Sometimes, but rarely, the unit could be damaged during shipping.
7. If there are no leaks, empty the system.

TROUBLESHOOTING

Emptying the System:

Empty the entire system while meeting local refrigerant handling standards. We recommend at least 30-45 minutes vacuum before charging. After the unit is empty, move to charging the system and charge it with the appropriate amount for freon.

Charge the System:

The system should be charged by a qualified A/C technician and follow the guidelines for R134a Freon.

ERROR CODES(I)

ERROR CODE	ERROR CODE	ERROR CODE
E01	Low voltage	<ul style="list-style-type: none">• Verify battery power.• Ensure correct connection of power line's positive and negative poles to battery.• Check for low protect voltage settings.
E02	Evaporator Motor Open Circuit	<ul style="list-style-type: none">• Loose or detached plug for evaporator motor.• Failure of internal control panel <p><i>Further Information: refer to appendix Error Codes (vi)</i></p> <ul style="list-style-type: none">• Ejected plug pin.

ERROR CODES(II)

ERROR CODE	ERROR CODE	ERROR CODE
E03	Compressor Failure	<ul style="list-style-type: none">• Loose screw on compressor phase line.• Compressor controller malfunction.
E04	Evaporator Motor Short Circuit	<ul style="list-style-type: none">• Connection issue with internal wire of evaporator motor.• Internal control panel malfunction.

ERROR CODES (III)

ERROR CODE	ERROR CODE	ERROR CODE
E05	Compressor Overheating	<ul style="list-style-type: none">• Check freon level.• Check for dusty condenser surface affecting heat dissipation.• Check for normal condensing motor speed.• Outside unit's narrow space causes poor heat dissipation.• Compressor controller failure.
E06	Condenser Fan Open Circuit	<ul style="list-style-type: none">• Loose/broken fan plug or line.• Ejected plug pin resulting in poor connection.• Compressor controller failure.

ERROR CODES (IV)

ERROR CODE	ERROR CODE	ERROR CODE
E07	Condenser Fan Short Circuit	<ul style="list-style-type: none">• Check for any short circuit in the condenser fan. <p><i>Further Information: refer to appendix Error Codes (vi)</i></p> <ul style="list-style-type: none">• Failure of the compressor controller.
E08 / E09 (Only B-COOL135000 has this error code)	1# (Red plug fan) / 2# (White plug fan) Condenser Fan Failure E08---1# E09---2#	<ul style="list-style-type: none">• The plug for the fan is either loose or the line is broken.• The plug pin is ejected, causing a poor connection.• The condenser fan motor is faulty.• The signal line for the condenser fan on the compressor controller has become disconnected.

ERROR CODES (V)

ERROR CODE	ERROR CODE	ERROR CODE
E10	Temperature Sensor Fault	<ul style="list-style-type: none">• Loose temperature sensor plug.• Ejected temperature sensor plug pins (poor connection).

ERROR CODES (VI)

Inspection method of E02

Disconnect the evaporator plug from the internal control panel and connect it to a 12V/24V power source. If the evaporator motor operates correctly, it indicates that the motor is functioning properly, but the internal control panel needs to be replaced. On the other hand, if the motor doesn't work, the evaporator motor needs to be replaced.

Inspection method of E07

If you connect the condenser fan to a 12V/24V power source and it functions correctly, then the condenser fan is not the issue, and you need to replace the compressor. However, if the condenser fan doesn't work, you should replace the condenser fan instead.

MAINTENANCE

Before beginning cleaning, make sure the air conditioner is turned off.

Surface Cleaning of inside unit:

Wipe with a clean damp cloth. The cloth can be dipped in a mild cleaning solution if the unit is very dirty.

Evaporator Core:

Clean with compressed air, if necessary.

Condenser Core:

Check for dirt and debris in the condenser core and condenser fan. Clean with compressed air, if necessary.

MAINTENANCE

If you operate the AC in a dusty/dirty environment,
Cleaning should be done more frequently.

- Check AC for excess dirt and dust
- Check evaporator
- Check Condenser Core
- Check Condenser Fan
- Check Drainage Plugs for clogs
- Apply common sense

MAINTENANCE

- Conduct regular maintenance.
- Start the unit at least once every two months.
- Check for blockage on the top and bottom of the condenser fan; the condenser coil and air flow before and after the evaporator blower

TECHNICAL SUPPORT

Should any problem occur during the operation of an air conditioner;
Please review the operating manual and/or contact our Tech Repair Center.



+1 778 590 5000

tech-help@dcpowersales.com



www.dcpowersales.com